

Technical Note # 3

FABRICATION TOLERANCES FOR CUT BRIAR HILL SANDSTONE

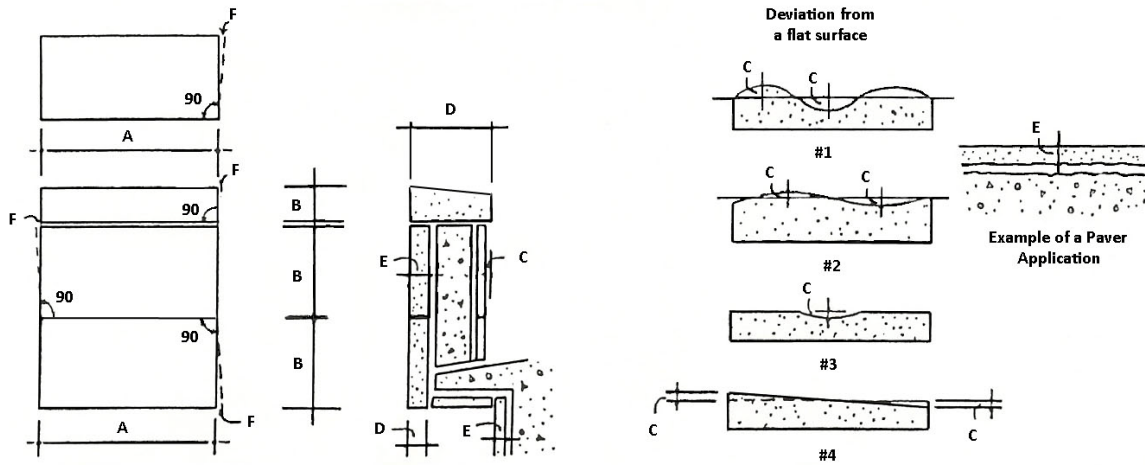

	A	B	C	D	E	F
	Length	Height	Deviation From Flat Surface Exposed Face	Critical Depth	Non-critical Depth	Deviation From Square
Smooth Finish	±1/8"	±1/8"	- 1/8" to + 1/8"	±1/8"	±1/2"	±1/8"
Massillon Split Face	±1/8"	±1/8"	- 1/2" to + 1/2"	±1/4"	±1/2"	±1/8"
Chat Sawed Face	±1/8"	±1/8"	- 1/4" to + 1/4"	±3/16"	±1/2"	± 1/8"

Tolerances C and F are measured within the length of a 4' - 0" straightedge applied at any angle on the face of the stone

Custom Finishes — Consult The Briar Hill Stone Company for texture variations, nominal thickness, and jointing.